

Assembling Instruction For W15

HARDWARE PART LIST

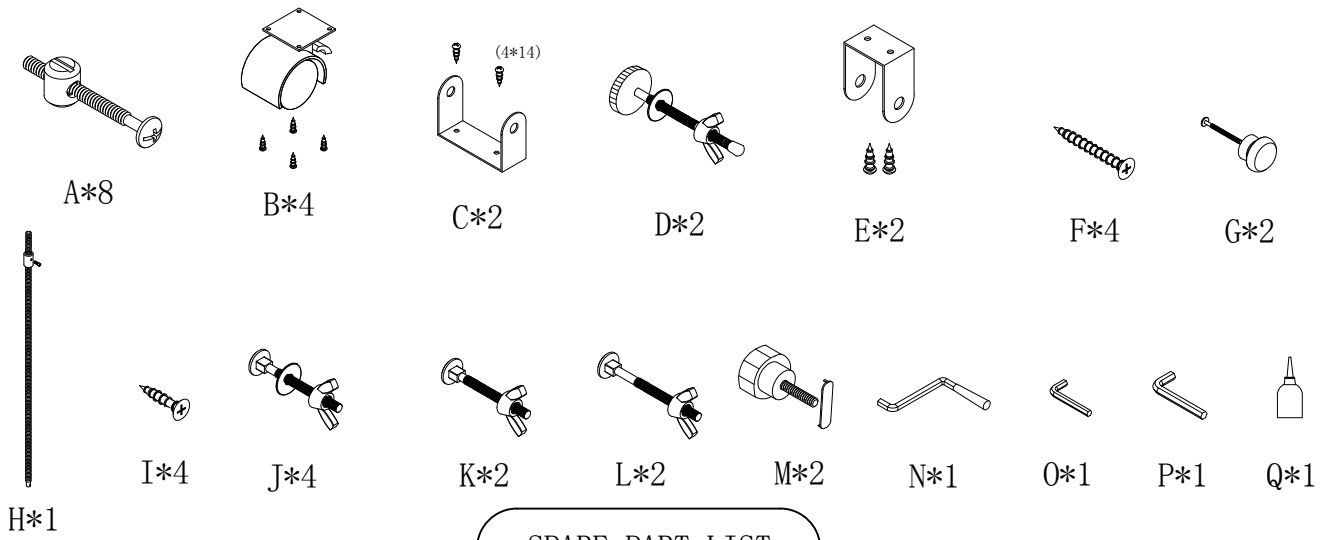

SPARE PART LIST

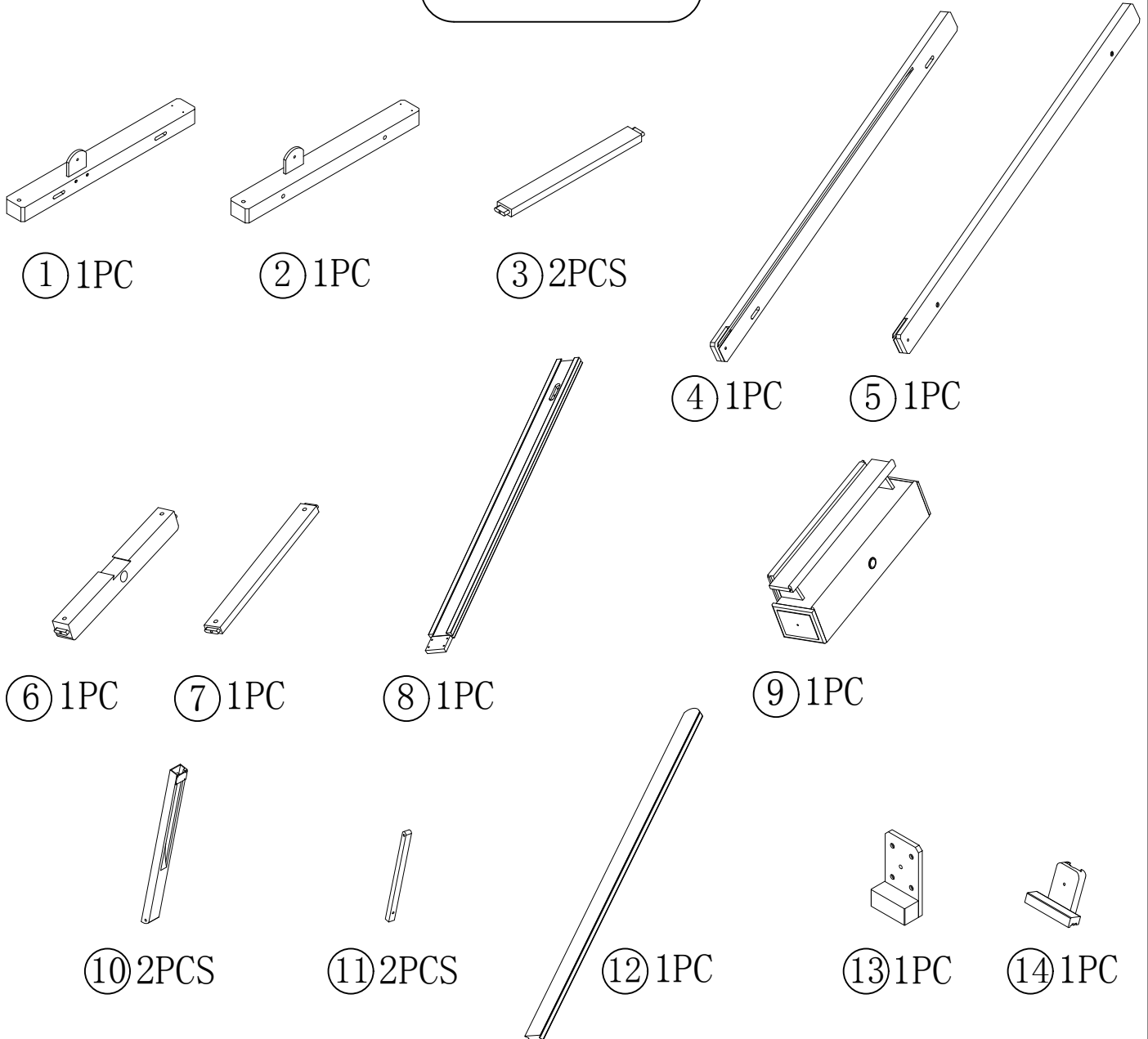

①

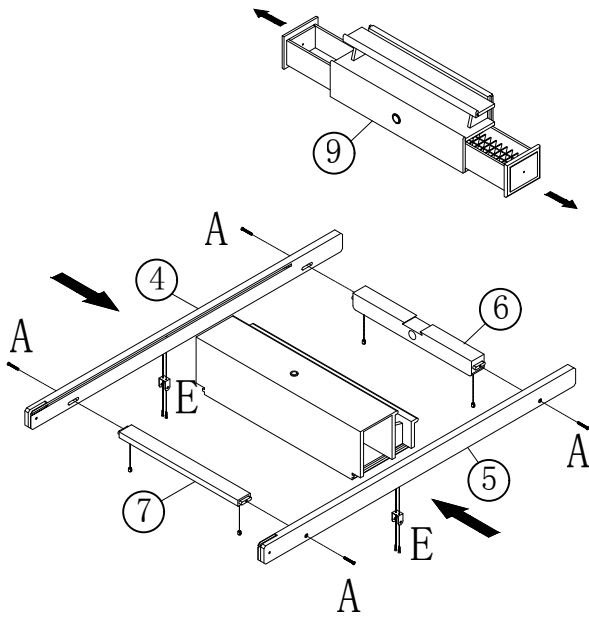

②

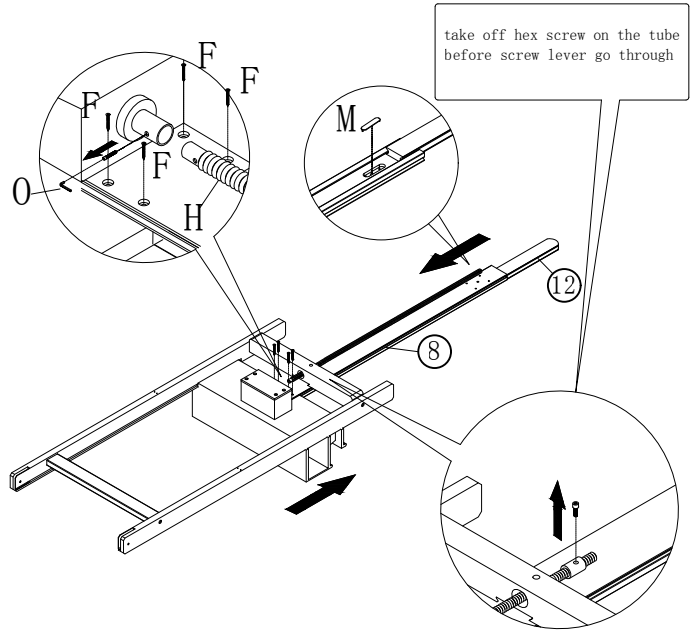

③

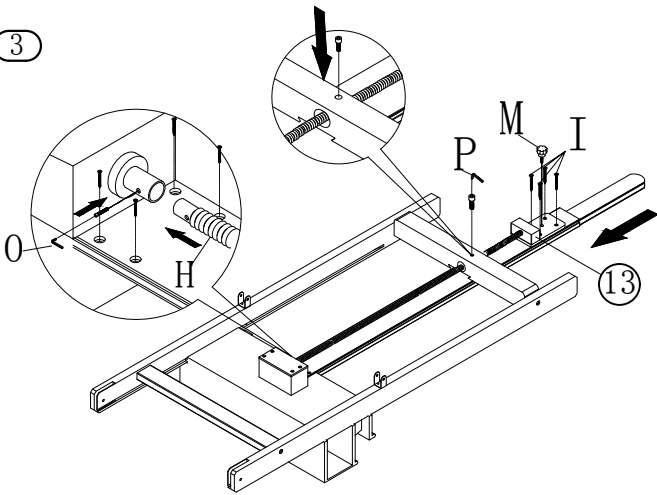

④

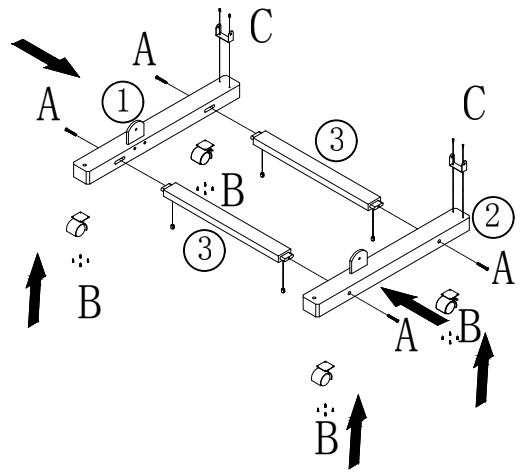

⑤

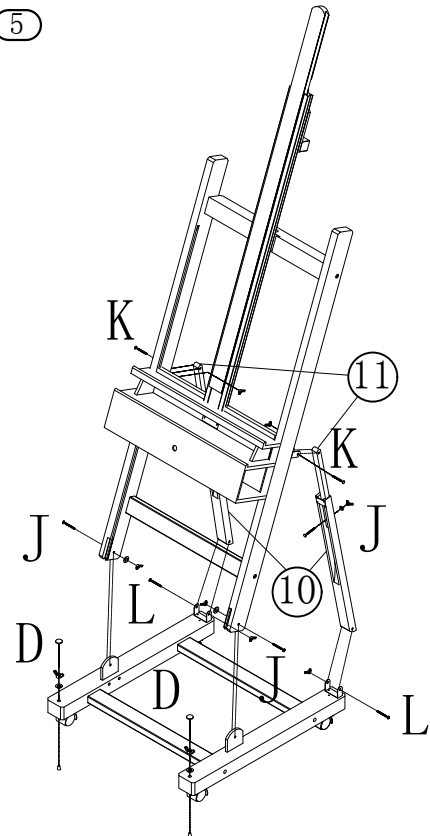

⑥

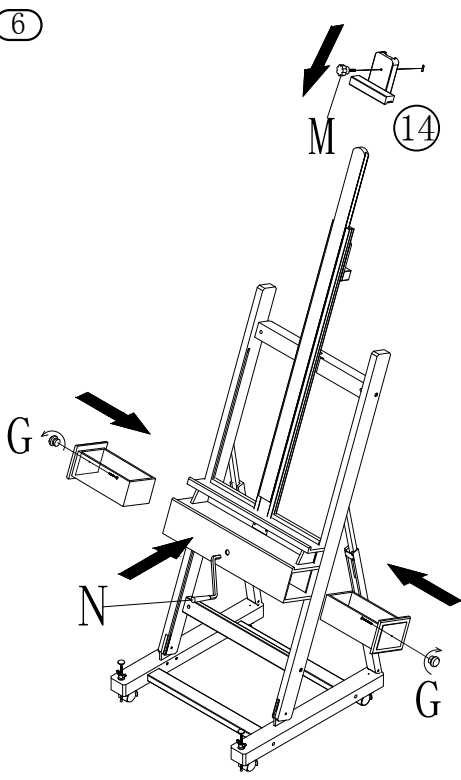

⑦

